

Case: Diam. 130 stainless steel 1.4301

Bezel: Stainless steel 1.4301

Dial: Aluminium, white varnished
lettering and graduation black
with dewpoint scale

Pointer: Aluminium, black
adjustable

Window: Plastic, raised

Measuring systems:
2 x bimetal for temperature
1 x rel. humidity

Measuring range:

Air:	-10...+40°C
Rel. humidity:	20...100%
Saturation moisture:	4...50 gr./m ³
Dewpoint temperature:	-8...+26°C
Surface temperature:	-10...+40°C

Features: Flexible measuring pot
for surface temperature

Accuracy class:

Temperature	± 1°C
Humidity	± 2.5%

Mounting method: With 3 bar magnets and a lifting lug

Diam. Article number:
130 Fig. 36 1530011



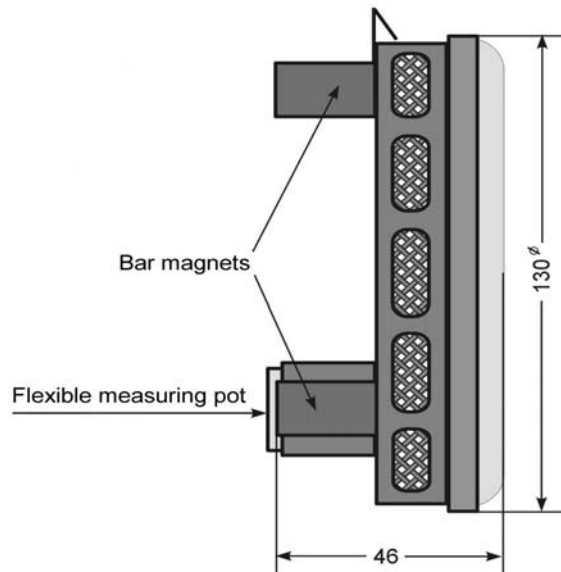

The thermo-hygrometer contains a precision humidity meter and two bimetal measuring systems. Here the temperature, the relative humidity, the saturation moisture and the dewpoint can be read off directly following the curves from the point of intersection of the surface temperature pointer and the relative surface humidity pointer. The back of the case is fitted with 3 strong bar magnets for steel part usage. The additional lifting lug at the top of the case gives the instrument an additional mounting method.

The instrument was developed for the requirements of the metallization and is normally used in the field of ship conservation, docks, bridges, steel constructions, mining and pipeline engineering.

At work in such fields of application it is possible to define directly the dewpoint temperature on the surface of the steel girder. This measurement has to convey certainty, that there will be no dewpoint precipitation. In the coating technic difficulties often arise because the paint doesn't stay on a wet base coat.

In order to make paintings fast, there is a decision of the German "Bundesministerium für Verkehr" that commands, that rust removing and painting works only can be done, if the temperature of the surface that shall be given a finish is min. 3°C higher than the dewpoint of the surrounding air. After fixing the combination to the surface of the material to be worked on, the measuring elements absorb the temperature and the relative humidity. This can take about half an hour depending on conditions. Thenafter the dewpoint can be read off in °C at the intersection of both pointers.

E.G. air temperature 9.5°C, rel. humidity 80% = 6°C dewpoint at 12°C surface temperature.

The difference between surface temperature and dewpoint temperature is 6°C, so that the conserving works can begin, because it is higher than 3°C.

The air temperature shows 9.5°C. This indicates that the surface temperature sinks slowly and a dewpoint precipitation is possible.

For that reason the testing should be repeated in certain intervals.

Masses and dimensions are conform to current company standard. Changes to improve our gauges will be made without preannouncement.