

Case:	Steel zinced - Stainless steel AISI 304
Bezel:	Steel nickel plated - Stainless steel AISI 304
Protection class:	IP 43
Dial:	Aluminium, white varnished lettering and graduation black - Red mark - Imprint - Double scale °C/°F
Pointer:	Aluminium, black adjustable at end of stem - Silicone damped
Window:	Instrument glass - Perspex window - Max. drag pointer (diam. 63-160) - Max./Min. drag pointer (diam. 63-160) - Red mark pointer (diam. 63-160)
Stem:	G 1/2 B brass detachable with fixing screw L = 28 / 45 / 50 / 63 / 100 mm solid A/F 21 Other lengths multi part soldered A/F 21 - Further connections see overleaf resp. 001
Connection:	Backwards
Measuring range:	0-120°C - Resp. opposite
Accuracy class:	1,6 - Accuracy class 1 (then the article number changes from 2XXX into 3XXX) - Works test certificate - OPTIONS

Diam.:		Article number:					
mm		34	50	63	80	100	160
Stem	28 mm	2030	2050	2060	2080	2100	2160
	45 mm	2031	2051	2061	2081	2101	2161
	50 mm	2032	2052	2062	2082	2102	2162
	63 mm	2033	2053	2063	2083	2103	2163
	80 mm	2034	2054	2064	2084	2104	2164
	100 mm	2035	2055	2065	2085	2105	2165
	120 mm	2036	2056	2066	2086	2106	2166
	160 mm	2037	2057	2067	2087	2107	2167
	200 mm	2038	2058	2068	2088	2108	2168
	250 mm	2039	2059	2069	2089	2109	2169

Measuring-range	Graduation
-40 +40°C	1°
-30 +50°C	
-20 +60°C	
-20 +40°C	
-15 +45°C	
-10 +60°C	
-10 +50°C	
1) 0 -40°C	
1) 0 -50°C	
0 -60°C	
0 -80°C	2°
0 -100°C	
0 -120°C	
0 -160°C	
0 -200°C	5°
0 -250°C	
0 -300°C	10°
0 -400°C	
2) 0 -500°C	
2) 0 -600°C	

Other lengths are available! Stem 28 mm only 0-100 and 0-120°C available!
Stem 45 mm shortest measuring span = 60°C!

1) shortest stem length 63 mm
2) stem stainless steel needed

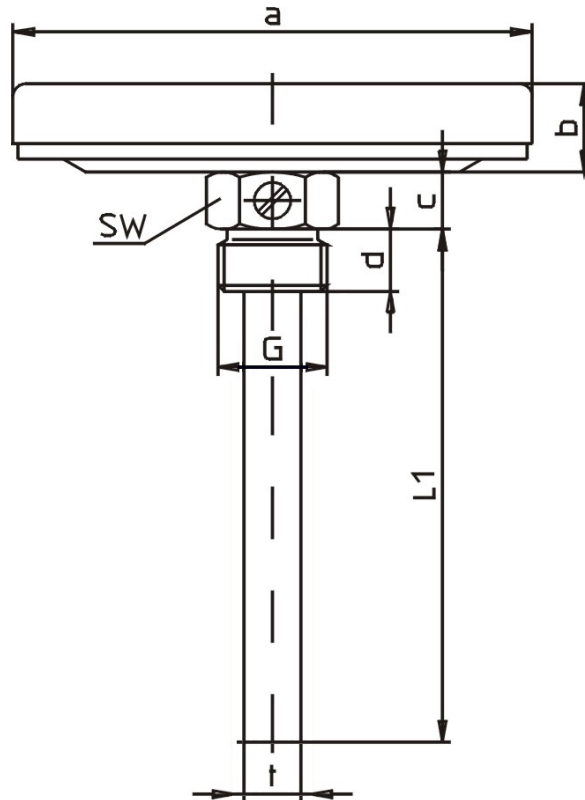

Type	a	b	c	d	SW	G	t
2030	34	9	11	12	21	½ B	12
2050	50	12	11	12	21	½ B	12
2060	63	13	11	12	21	½ B	12
2080	80	13	11	12	21	½ B	12
2100	100	15	11	12	21	½ B	12
2160	160	19	11	12	21	½ B	12

0	1	2	3	4	5	6	9
separate pocket with male thread and fixing screw	fixed connection male thread	union nut female thread	union nut with double nipple male thread	union nut with additional thermowell acc. to DIN 43 772 form 8	turnable male thread	movable clamp connection male thread	separate pocket for welding with fixing screw

Dimensions and technical data are conform to current company standard.
 Changes to improve our instruments will be made without preannouncement.